

CCD Photodetector Head
C7222
TECHNICAL SPECIFICATION

HAMAMATSU

Contents

Contents

Introduction	-----	2
Structure	-----	3
Setting Up	-----	6
Operation	-----	7
Specifications	-----	8
Connector Pin Arrangement	-----	10
Spectral Response Characteristics	-----	11
Handling Precautions	-----	12
Appendix	-----	13
External Dimensions	-----	14

Introduction

Introduction

The C7222 is a highly sensitive, multichannel CCD photodetector head specifically developed for spectrum measurements at extremely low light levels. The C7222 measures light levels that are too faint for conventional image sensors.

The C7222 uses a back illuminated FFT-CCD image sensor for its photodetector. This type of sensor features low-noise operation, and high Quantum Efficiency(QE) enabling measurement of fluorescence, Raman spectra, and other such weak light phenomenon.

The photodetector head incorporates the FFT-CCD sensor (with internal cooler), a specialized low-noise drive circuit, and a temperature control circuit offering excellent temperature stability. The head is easily controlled by input of external signals. The temperature-control circuit begins cooling the head to the preset temperature (-15°C) as soon as power comes on, so as to reduce the dark current. A special protection circuit automatically cuts power off if temperature rises as a result of cooler failure.

The C7222 utilizes a compact, heat-releasing design. It does not require water cooling, and is extremely easy to operate.

Structure

Structure

The photodetector head consists of the following four sections.

- FFT-CCD image sensor, with internal cooler
- Drive circuitry
- Temperature-control circuitry
- Case

Fig. 1 Block Diagram

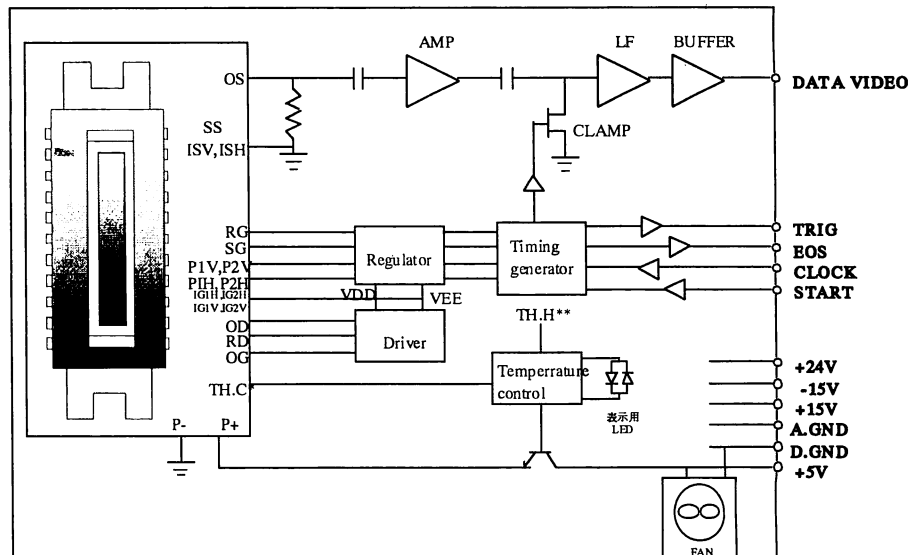

- * : Thermistor built into sensor; monitors the sensor temperature.
- ** : Thermistor on sensor fins ; monitors the fin temperature.

FFT-CCD
image sensor

FFT-CCD Image Sensor with Internal Cooler

The FFT-CCD (full frame transfer CCD) design is fundamentally different from the ITT-CCD (interline transfer CCD) typically used in video cameras. Unlike an ITT-CCD, the FFT-CCD combines the charge-transfer section with the photodetector section. The FFT-CCD offers a variety of advantages over ITT-CCD technology, including lower dark current, 100% fill factor, and very low residual images.

Although the sensor is a 2-dimensional CCD, all electrical charge in the vertical direction is added to the corresponding horizontal vertical registers (a process referred to as vertical binning, or more simply as binning.) This makes it possible for the C7222 to function as a one-dimensional image sensor with a large photosensitive area so that it can be used, just as a conventional image sensor, with a spectroscope or in other such applications. The package includes an internal electronic cooler (one-level Peltier element) that cools the photosensor elements to -15°C , thereby reducing the dark current so as to enable the image to be accumulated over a longer time.

Structure

Drive Circuitry

The drive circuitry supplies the various timing signals to the sensor, and executes low-noise signal processing on the analog video signal received from the sensor. The system is driven by two external control signals (START and CLOCK), and four power signals (+5V, +15V, -15V, and +24V).

Timing-signal generator section

This section consists of a counter and EPROM. The timing signals are generated in sync with an externally supplied master clock pulse (CLOCK). An externally supplied start pulse (START) initializes the signal generation operation.

CCD driver section

This section converts the timing signals to the level required by the sensor. Specifically, it converts signals from H-CMOS level to VL=VEE, VH=VDD levels.

Voltage-regulator section

This section generates the various voltages required by the sensor. The regulator provides highly precise, highly stable low-noise voltages.

Video-signal processing section

This is a 3-stage amplifier section that implements low-noise processing of the analog signal from the sensor. The first stage is a low-noise amplifier that amplifies the video signal. The second stage, comprised of a DC generation circuit and secondary low-pass-filter circuit, eliminates reset noise (generated at the sensor side) and high-frequency noise. The final stage is an inverter amplifier (with a gain of 1) that produces the positive-polarity output required for direct coupling to the external ADC. The generated output has low impedance, so that it is not disturbed by external noise.

Note: Impedance does not output to 50 or 75 ohms.

Structure

Temperature-
Control Circuitry

Temperature-Control Circuitry

This circuit monitors the sensor temperature (using a thermistor built into the sensor) and controls power to the electronic cooler accordingly so that the sensor is cooled to the preset temperature ($T_s = -15^\circ\text{C}$). Power supply to the cooler (over the +5V line) begins when the unit is switched on.

The temperature-control circuitry includes a protection circuit that automatically switches off power to the cooler in the event that cooler failure results in overheating.

Case

The case, which supports the sensor cooling fins and the fan, provides a compact design with good heat-release characteristics. The front of the case includes mounting holes that can accept attachment of a spectroscope or other such device.

Note: The fan, located at the rear of the case, blows air onto the sensor fins to promote cooling. Please be sure to leave adequate space at the top and bottom of the unit to allow air from the fins to escape.

Setting Up

Setting Up

Power connections

Connect power for the digital signal to the +5V line, and power for the analog signal to the 15V, -15V and +24V lines.

The digital and analog grounds are connected at an optimal location within the circuit, and should be separated as far as possible externally. Use a low-noise, low-ripple power source; and use wide power cables so as to secure low impedance. It is especially important to use wide cable for the +5V line, as this connects to the electronic cooler built into the sensor.

Note: If you are mounting the photodetector head within another device, give adequate consideration to electropotential relationships among the devices when connecting the grounds.

Pulse-generator connection

The pulse generator supplies the START and CLOCK signals required to drive the detector head. For electrical specifications, refer to the Specifications section.

Oscilloscope connection

Connect the DataVideo terminal to the oscilloscope input terminal. You will also need to input the pulse generators START pulse signal into the oscilloscope's Ext. Trig terminal in order to obtain video sync. Use shielded signals to protect the video signal from the effect of external noise.

Hamamatsu Photonics offers a compact PMA Controller (model C7223) that provides power sources, timing signals, A/D conversion, and an SCSI computer interface. For details, refer to the PMA-50 catalog.

Operation

Operation

Supplying Power

Check the +5V, +15V, -15V, and +24V power voltages before setting power on. Make sure that current is normal. If you detect an overcurrent you should cut the power voltages immediately, as there may be a short circuit in the power voltages line.

Note that current on the +5V line starts out at about 3A, but then drops briefly before stabilizing between 2 and 2.5A.

Supplying Control Signals from the Pulse Generator

Use a pulse generator to supply the START and CLOCK signals required to drive the detector head. These must be H-CMOS level signals; use of a different signal level will result in misoperation. The START signal must have a pulse width that is at least as long as 1 CLOCK period, and should be kept in sync with the CLOCK signal insofar as possible.

The frequency of the CLOCK signal determines the DataVideo readout frequency. The pulse interval of the START signal determines the sensor's accumulation time.

[Image Accumulation-Time Setting]

The following shows how to calculate the image accumulation time.

Operation

(Example) Where CLOCK-signal frequency is 250kHz

Readout of the DataVideo signal occurs at 1/4 the CLOCK frequency, so that readout time per channel is 16us ($t_v = 16\mu\text{s}/\text{ch}$). If one scan time includes binning time, then:

$$T_{\text{scan}} = t_v \times (N_v + N_h)$$

N_v = number of vertical-register channels

N_h = number of horizontal-register channels

C7222-0906

$$\begin{aligned} T_{\text{scan}} &= 16 \mu\text{s} / \text{ch} \times (64+532) \text{ ch} \\ &= 10\text{ms} \end{aligned}$$

C7222-0907

$$\begin{aligned} T_{\text{scan}} &= 16 \mu\text{s} / \text{ch} \times (128+532) \text{ ch} \\ &= 11\text{ms} \end{aligned}$$

C7222-1006

$$\begin{aligned} T_{\text{scan}} &= 16 \mu\text{s} / \text{ch} \times (64+1044) \text{ ch} \\ &= 17\text{ms} \end{aligned}$$

C7222-1007

$$\begin{aligned} T_{\text{scan}} &= 16 \mu\text{s} / \text{ch} \times (128+1044) \text{ ch} \\ &= 19\text{ms} \end{aligned}$$

Specifications

Specifications

■ Absolute Maximum Ratings

Parameters	Symbol	MIN.	TYP.	MAX.	Units
Power voltage (digital system)	+ VD			+ 7	V
Power voltage (analog system)	± VA1			± 18	V
	+ VA2			± 30	V
Digital input voltage				+ VD	V

■ Electrical specifications (at following conditions, unless otherwise specified: Ta=20°C; VD=+5V; -VA1=-15V; VA2=+24V)

Parameters	Symbol	MIN.	TYP.	MAX.	Units
Digital input					
H-level voltage	VIH	+ 2		+ VD	V
L-level voltage	VIL	- 0.5		+ 0.8	V
Master clock (CLK) pulse frequency	fCLK			250	kHz
Video-signal readout frequency	fv			fCLK/4	Hz
Master start (Start) pulse frequency	tst			1/fCLK	Sec
Digital output					
H-level voltage (Io=-6mA)	VIH	+ 2.0			V
L-level voltage (Io=+6mA)	VIL			+ 0.8	V
Voltage conditions					
Rated voltage: Digital	+ VD	+ 4.75	+ 5.0	+ 5.25	V
Analog	± VA	± 14.5	± 15.0	± 15.5	V
	+ VA2	+ 23.5	+ 24.0	+ 24.5	V
Current consumption:					
+ 5VDC (*1)				+ 4.0	A
± 15VDC				+ 100	mA
+ 24VDC				- 100	mA
Temperature range					
Operating (Ta)		+10		+ 30	°C
Storage (Tstg)		0		+ 50	°C

*1: Includes current consumed by image sensors built-in Peltier element.

Specifications

■ Photoelectrical specifications (at following conditions, unless otherwise specified: Ta=20°C; Ts=-15°C; VD=+5V; -VA1=-15V; VA2=+24V)

Parameters	Symbol	MIN.	TYP.	MAX.	Units
Wavelength sensitivity range	SR	200		1000	nm
Saturation output charge (*2)	Fw		600k		e-
Readout noise charge	Nr		20		e-
Dark output charge (*3)	DS		30		e-/pixel/sec
Dynamic range	DR		30k		
Dark-current uniformity (*4)	DSUR			± 30	%
Sensitivity uniformity (*4)	PSUR			± 10	%
Conversion gain (*5)	Sv		30.5		μ V/e-

*2: Horizontal-register value.

*3: Vertical-register value. For binning, gives vertical pixel summation.

*4: Measured at 50% saturation output charge.

*5: Including circuit gain.

■ Temperature-control section (at following conditions, unless otherwise specified: Ta=20°C; Ts=-15°C; VD=+5V; -VA1=-15V; VA2=+24V)

Item (*6)	Symbol	MIN.	TYP.	MAX.	Units
Cooling temperature	Ts	- 13	- 15	- 17	°C
Controlled temperature range	Δ Ts	- 0.05	k	+ 0.05	°C
Peltier power consumption	Pp			7	V
Time to reach set temperature	tO			10	min
Sensor overheat-protection temperature	To	+ 30			°C

*6: The following functions are also included.

Error display

Short circuit/wire-break detection for sensor-internal thermistor

Automatic power-OFF function

■ Pixel size

Heads	Total Pixels Pixels(H) × Pixels(V)	Effective Pixels Pixels(H) × Pixels(V)	Effective Area mm(H) × mm(V)
C7222-0906	532 × 64	512 × 58	12.288 × 1.392
C7222-0907	532 × 128	512 × 122	12.288 × 2.928
C7222-1006	1044 × 64	1024 × 58	24.576 × 1.392
C7222-1007	1044 × 128	1024 × 122	24.576 × 2.928

Connector Pin Arrangement

D-Sub 15-pin connector

Pin arrangement

Pin	Name	Function
1	DataVideo	Analog video output signal
2	NC	Not connected
3	START	Circuit-initialization digital input signal H-CMOS compatible; positive logic Sensor exposure time is equal to pulse interval.
4	CLOCK	Circuit-starting digital input signal H-CMOS compatible; positive logic
5	TRIG	Circuit-starting digital output signal H-CMOS compatible; positive logic
6	EOS	Circuit-initialization digital output signal H-CMOS compatible; negative logic
7	+VD (+5V, P+)	Digital power; power to sensor-internal electronic cooler
8	+VD (+5V, P+)	Digital power; power to sensor-internal electronic cooler
9	D. GND (P-)	Digital ground
10	+VA1 (+15V)	Analog power
11	-VA1 (-15V)	Analog power
12	+VA2 (+24V)	Analog power
13	NC	Not connected
14	A. GND	Analog ground (Analog video output signal Return)
15	NC	Not connected
16	D. GND	Digital ground
17	D. GND	Digital ground
18	D. GND	Digital ground
19	D. GND	Digital ground
20	+VD (+5V, P+)	Digital power; power to sensor-internal electronic cooler
21	D. GND (P-)	Digital ground
22	D. GND (P-)	Digital ground
23	A. GND	Analog ground
24	A. GND	Analog ground
25	NC	Not connected

Spectral Response Characteristics

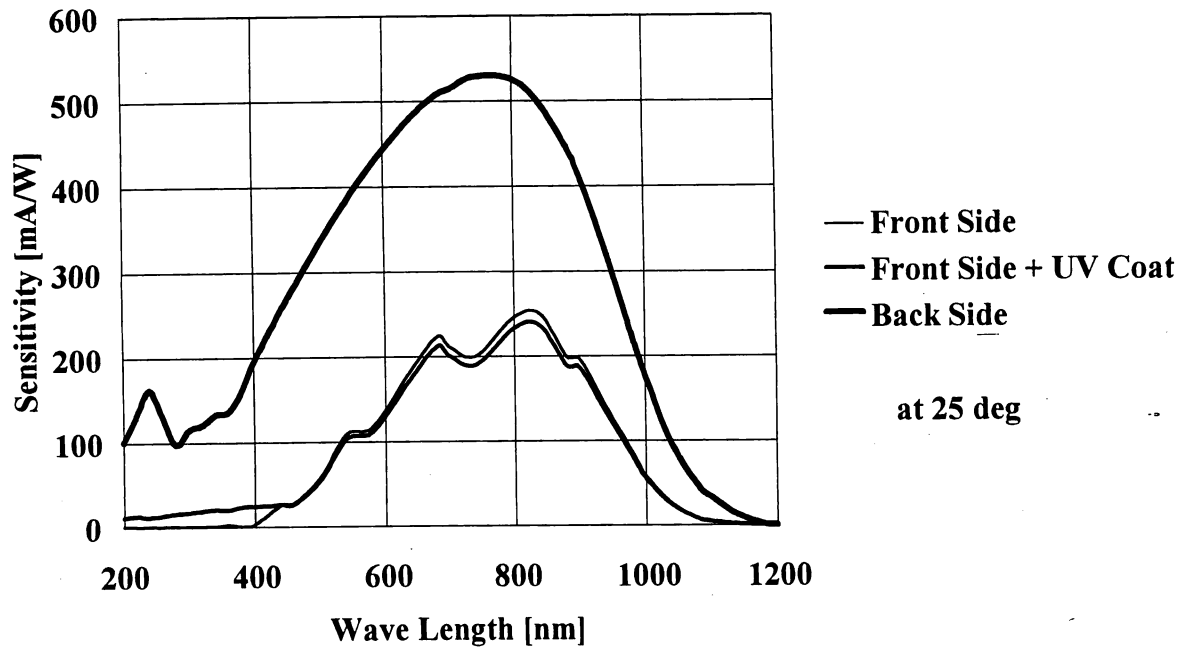

Spectral Response Characteristics of CCD

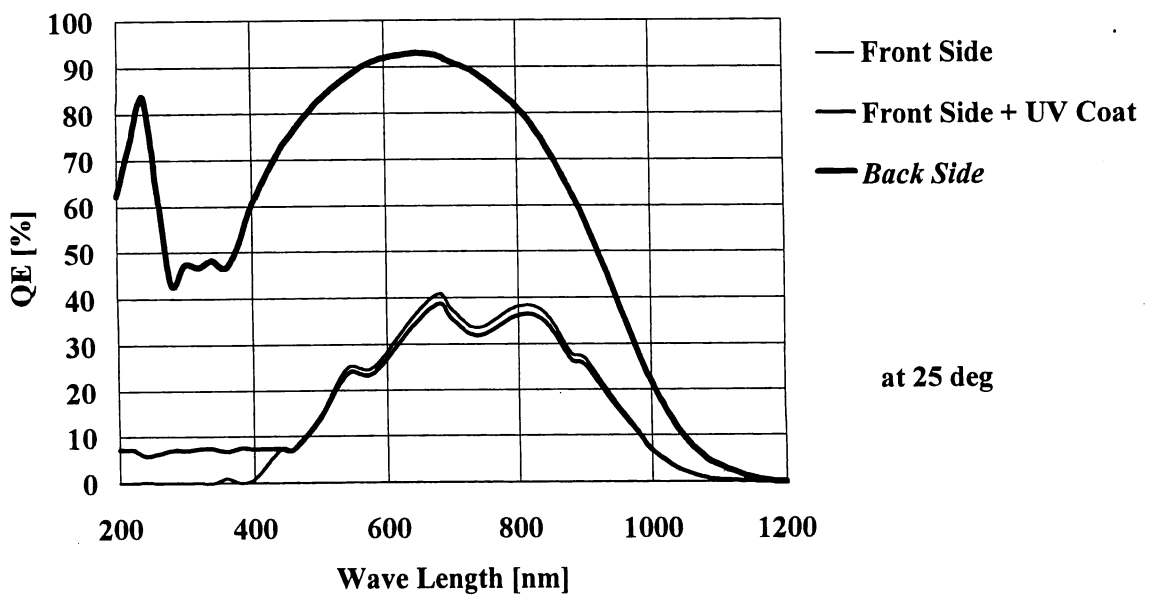

Handling Precautions

Handling Precautions

Please observe the following precautions when using the C7223 image sensor.

- Do not disassemble or modify the unit, as this may result in damage.
- Do not drop the unit or expose it to other sharp impact. Strong impact can cause the unit to break.
Avoid exposure of sensor to extraneous light, as this may cause loss of sensitivity.
- Do not leave the unit exposed to high temperature or humidity for protracted periods.
- Be careful when connecting the unit to other devices.
- Never exceed absolute maximum ratings when using the unit.
- Do not block the ventilation slits at the top and bottom of the unit during use. Blocking the slits may cause the sensor to overheat.

The following precautions will help to ensure high-precision measurements.

- Be sure to use adequate shielding to protect against electromagnetic interference. Use of shielded cables is recommended.
- Use of a low-noise, low-ripple power source is recommended.
- To ensure precision, be careful to prevent entry of extraneous light during measurement.

Appendix

Timing Chart

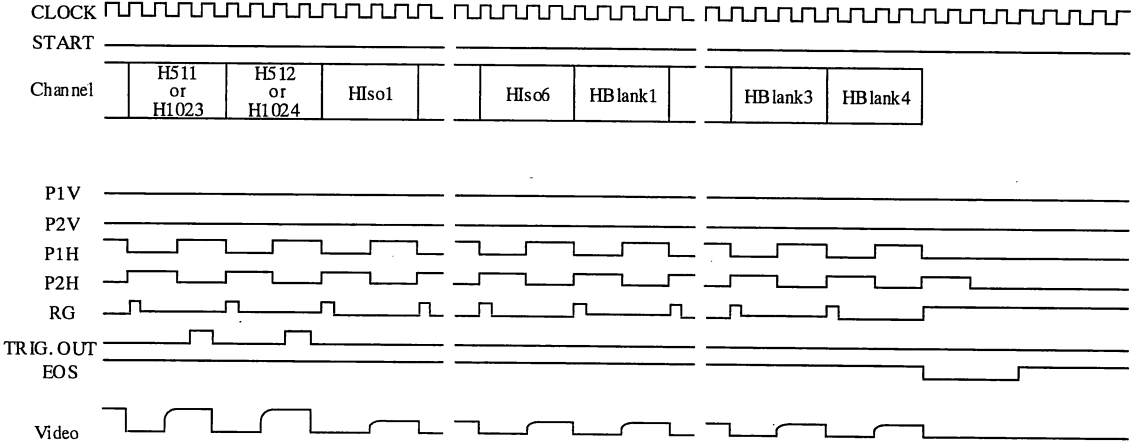
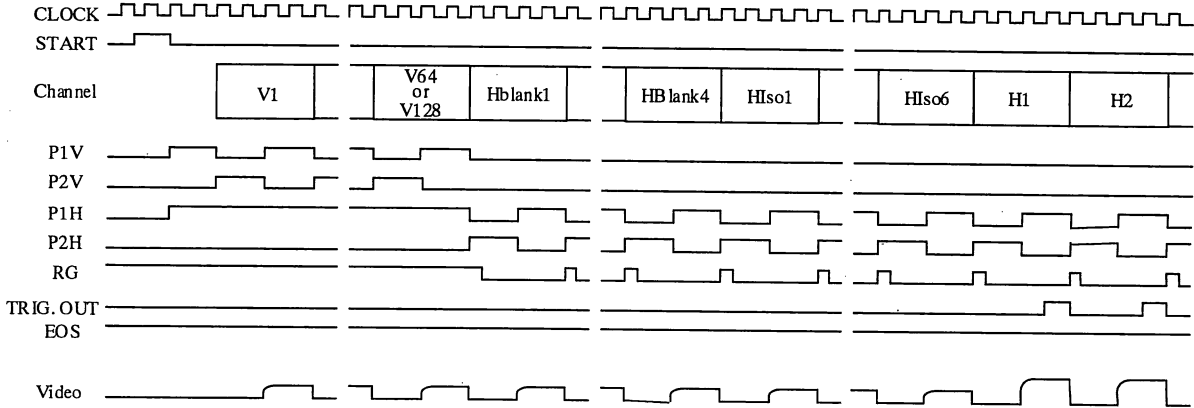

External Dimensions

Outline dimensions(mm)

